

MODEL 2025E-HF

HIGH FREQUENCY VIBRATION SHAKER

- Wide useable frequency range up to 20 kHz
- Provides up to 13 lbf (58 N) pk sine force
- Compact and portable weighing just 11 lb (5 kg)
- 2.125 in (54 mm) diameter mounting platform with multiple internally threaded attachment points
- Trunnion base for flexible rotation and alignment

TYPICAL APPLICATIONS

- Production Screening
- Accelerometer Calibration
- High Frequency General Vibration Testing

20 KHZ RANGE SHAKER

The Modal Shop 2025E-HF High Frequency Vibration Shaker is a 13 lbf (58 N) sine-peak electrodynamic unit. The shaker is designed for general purpose vibration testing of small components and stress screening of electronic sub-assemblies. The shaker has an extended frequency range for use in calibration of accelerometers and general-purpose high frequency testing. The compact size of the 2025E-HF shaker (11 lb/5 kg total) and large specimen mounting table surface (2.125 in/54 mm diameter) with multiple internally-threaded attachment points make the shaker assembly ideally suited for such applications as production screening, accelerometer calibration and high frequency testing.

The shaker is supplied in a standard trunnion mounting base allowing operation through a large rotation for easy set-up. Its armature suspension design provides excellent axial compliance with high lateral stiffness. There is no rolling or sliding components to wear out or produce unwanted noise and distortion. Its 0.5 in (13 mm) stroke and wide frequency range up to 20 000 Hz make the 2025E-HF a great choice for small component testing.

SPECIFICATIONS

Performance

Output Force, sine pk, ambient air cooling	13 lb (58 N) ^[1]
Stroke Length, pk-pk	0.5 in (12.7 mm)
Frequency Range, nominal	DC - 20000 Hz ^[2]
First Resonance Frequency, nominal	> 5500 Hz ^[2]
Maximum Velocity	100 in/s (2.54 m/s) pk
Maximum Acceleration, bare table	100 g pk
Maximum Acceleration, peak shock	300 g pk
Maximum Acceleration, resonance	150 g pk

Physical

Platform Mounting Thread	10-32 center 6-32 on 1.8 in B.C.
Armature Weight	0.35 lb (0.159 kg)
Suspension Stiffness	15 lbf/in (2.6 N/mm)
Rated Drive Current, ambient air	13 A rms
Stray Magnetic Field, 1 in (25.4 mm) above table	<15 Gauss
Stray Magnetic Field, 0.5 in (12.7 mm) above table	<15 Gauss
Dimensions (H x W x D), nominal	6.88 x 5.5 x 4.25 in (174.6 x 139.7 x 108 mm) ^[3]
Weight, nominal	11 lb (5 kg)
Operating Range	40 – 100 °F (4 – 38 °C), < 85% RH

Supplied Accessories

Shaker Cable 10 ft (3 m)
Shaker Cable Spare Fuse
7/64" hex wrench
3/16" hex wrench

Suggested Accessories

2100E21-400 SmartAmp™ Power Amplifier, voltage mode
301A10 Double-ended reference accelerometer, ICP®, 100 mV/g, 0.5 to 10 000 Hz, 1/4-28 bottom & top

ORDERING INFORMATION

K2025E013-HF Electrodynamic Exciter Kit. Includes 2025E-HF shaker, 2100E21-400 power amplifier, cable, and trunnion mounting base

[1] 13 lbf (58 N) sine pk up to 14 kHz. 7 lbf (31N) sine pk from 14 kHz to 20 kHz

[2] Load dependent, stated specifications based upon bare table.

[3] Reference outline drawing for details

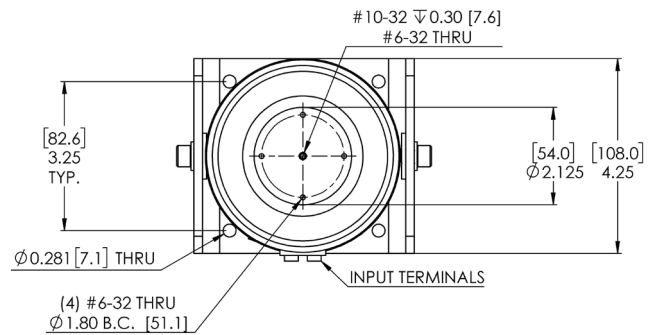

Model K2025E-HF Top View

Dimensions in inches

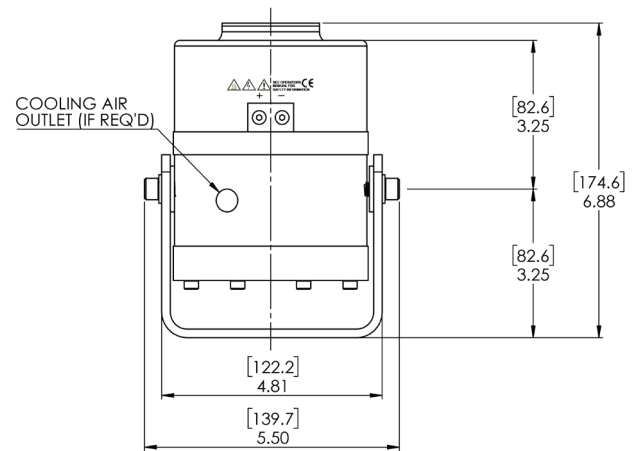

Model K2025E-HF Front View

Dimensions in inches